

Products: Vanities / Screens	Product Codes: RV and RS
Approved Publication Date: October 2010	

Vanities and Screens

Resco vanities are perfect for public and commercial ablution areas. Vanities are made to last using Compact Laminate so they are perfect in these wet, and often high use and abuse areas.

Resco's Vanities are a cost effective, easy to install, custom made unit. Dirt traps have been minimised meaning easy cleaning.

Recommended for

- Public areas
- Schools
- Sport & Recreational areas
- Community Clubs
- Camping & Caravan sites
- Shopping centres
- Offices
- Hotel complexes

Features

Specific qualities of Resco's Vanities and Screens

- Wide range of colours and finishes
- Strong and durable – 'built-for-purpose'
- Easy to clean and low maintenance
- Cost effective design
- 13 mm prefinished Compact Laminate panels

Screens

- Privacy and modesty screens to match your colours

Vanities

- Customised to suit your space
- Suitable for high and low water pressure systems

Edge treatment

- No edging is required as Compact Laminate is a finished product, a simple furniture oil enhances the black edge



Standard materials and manufacture

- 13 mm Compact Laminate

Vanities

- Single lever basin mixer(s)
- Mercer G-9 Stainless steel Under bench mounted sink 300 mm wide x 120 mm deep
- Galvanised support brackets
- Single lever basin mixer

Screens

- Powder coated Aluminium extrusions

Options

Vanities

- Different configurations are available, including corner, single, double or triple sinks

Screens

- Full screens
- Modesty screens
- Kindy screens
- Shower screens

Colours

Panel Colours

Resco vanities and screens are available in the Maica Compact Laminate stock colour range and the Laminex Compact Laminate range.

The Maica Accent colour range is also available on a 12-week lead time.

Aluminium Colours

Extrusions are available in any of the Duralloy powder coating colour range from Dulux.

See the Web site or call for samples.

Vanities & Screens
Perfect for wet and high abuse areas

Dimensions

As vanities are custom made to your measurements, depths and widths, they can be varied to suit.

Standard vanity dimensions are:

- 1 Sink and mixer
900 mm wide x 500 mm deep
x 250 mm high
(plus 100 mm high splash screen)
- 2 Sinks and 2 mixers
1800 mm wide x 500 mm deep
x 250 mm high
(plus 100 mm high splash screen)
- 3 Sinks and 3 mixers
1800 mm wide x 500 mm deep
x 250 mm high
(plus 100 mm high splash screen)
- 6 Sinks and 6 mixers
3600 mm wide x 500 mm deep
x 250 mm high
(plus 100 mm high splash screen)

Durability and maintenance

- Compact Laminate panels means an extended product life
- Being a tough durable product it is perfect for high traffic locations and because it is impervious to water it is ideal in wet areas
- Easily cleaned with mild detergent
- 10-year guarantee on panel integrity and 2-years on hardware



Installation

Resco has an installation service available. Or customers can install themselves as Resco cubicles come as a kitset delivered to site, which include installation manuals and hardware.

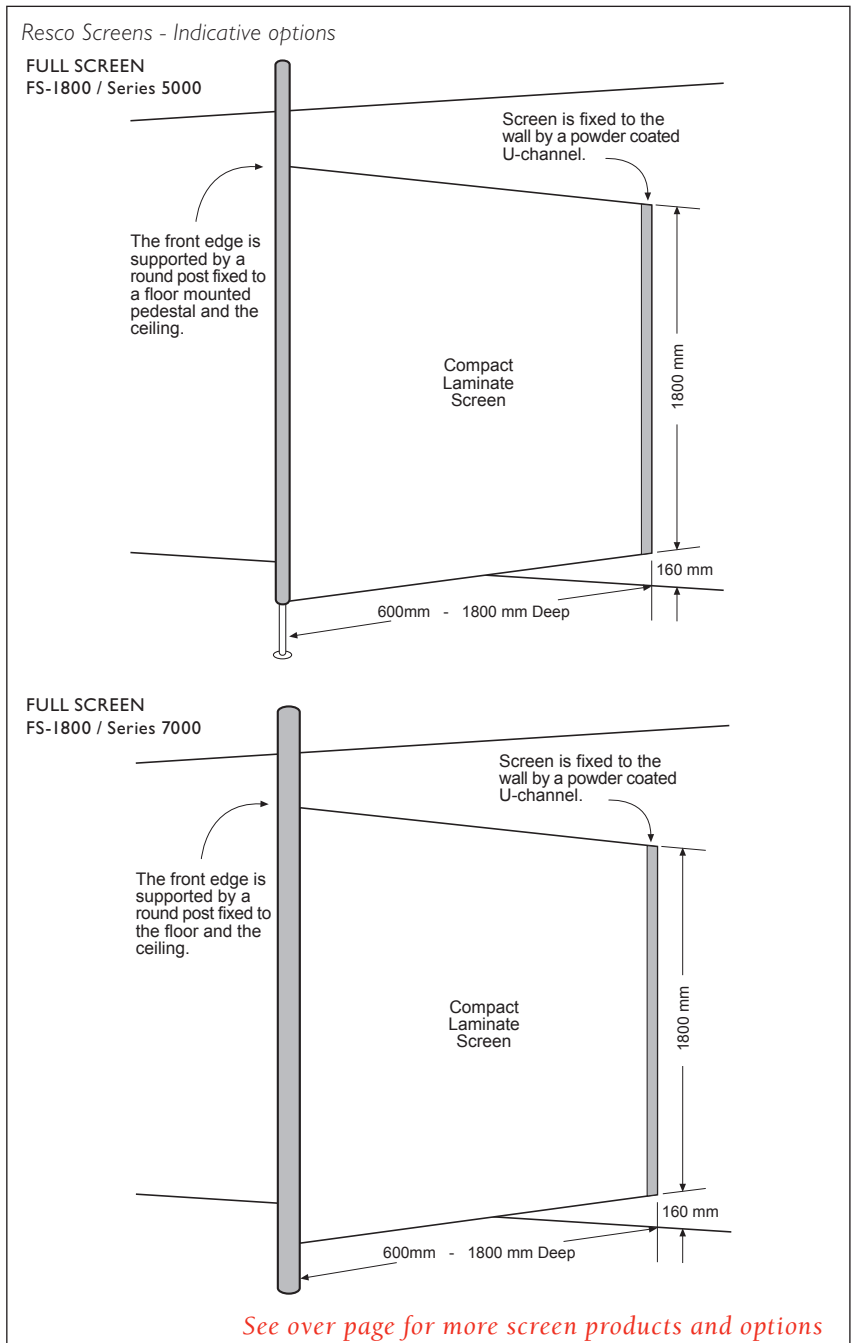
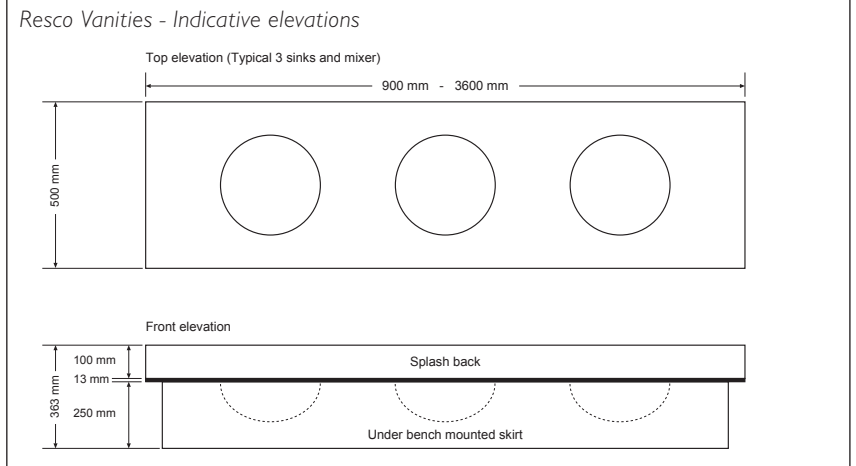

This information may change without notice.

Vanities&Screens
Perfect for wet and high abuse areas

Resco shower screen - Indicative elevation

SHOWER SCREEN SC-1700

Shower screen can be either a Compact Laminate panel or curtain.

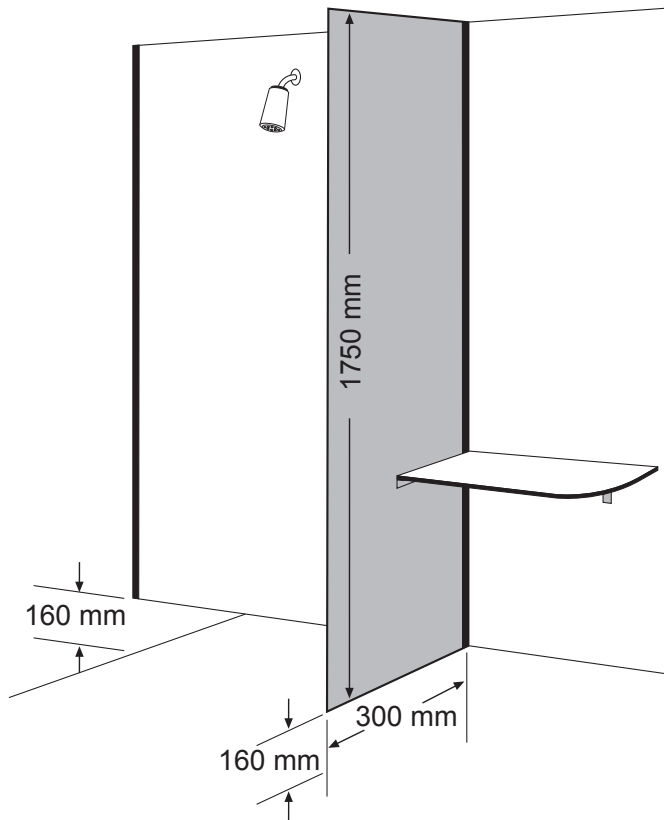

Resco screens - Indicative elevations

MODESTY SCREEN MS-900

Screen is fixed to the wall by a robust 75 mm half-rounded aluminium extrusion finished in satin anodising.

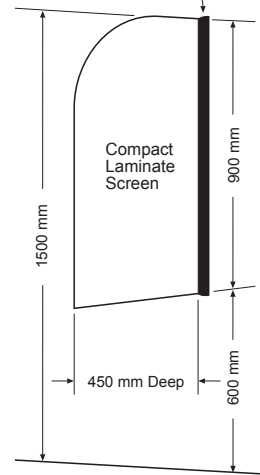

KINDY SCREEN KS-1200

Screen is fixed to the wall by a powder coated U-channel.

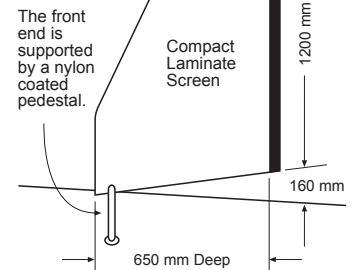

Resco shower seats - Indicative elevations

SHOWER SEAT SC-900p (shower panel option)

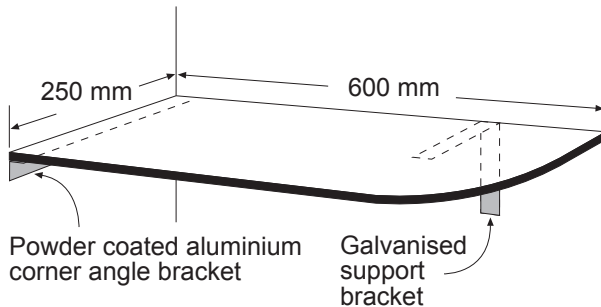

SHOWER SEAT SC-900c (shower curtain option)

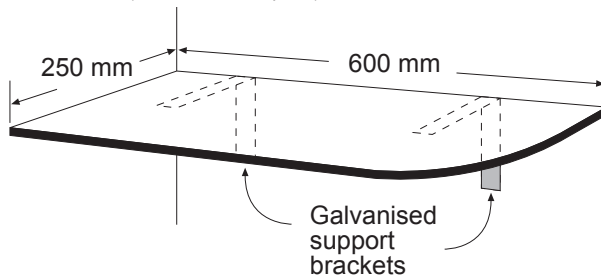

Contact

For pricing, email your plans or drawings to:

info@resco.co.nz
or fax **07 850 1026**.

Call Resco on **0800 800 950** for their full range or visit the Web site **www.resco.co.nz** and click on **Vanities/Screens**.

RESOCO

Resco Ltd
23a The Boulevard
Te Rapa Park
Hamilton 3200

This information may change without notice.

Vanities&Screens
Perfect for wet and high abuse areas