

MULTICUBE™

Suspended Partitioning System

Multicube™ Toilet Partitions are not fixed to the floor and not attached to the ceiling.

Resco NZ Ltd specialises in the design and manufacturing of Compact Laminate propriety cubicle systems and related products, based on the latest Compact Laminate panel technology.

SPECIFICATIONS

- 13mm prefinished Compact laminate panels
- Suspended off the floor using Multicube headrail
- In line doors flush with rebated fascias
- Aluminium hinges with nylon bushes and s/s pin, finished in silver satin
- Die cast indicator turning bolt, finished in silver satin
- Die-cast coat hook/doorstop finished in chrome plate

FEATURES

- The innovative suspended concept offers a strikingly uncluttered and aesthetically pleasing design statement
- Compact laminate “fit-for-its-purpose” panels are ideal for harsh environments like ablution blocks
- S/S drop hinges available at no extra cost
- State of the art machine produced components
- Ease of installation

BENEFITS

- Easy to clean environment
- Compact laminate panels extend the life of the system
- Panels will not lose integrity even after wilful damage
- S/S drop hinges allow for unoccupied cubicles to be clearly visible

SUSTAINABILITY

- Compact Laminate panels are manufactured incorporating thermal energy recovery systems
- About 75% of the core material is processed fast growing soft wood material grown on traceable forest farms
- Energy is recoverable through thermo recycling

PANEL COLOUR RANGE

MAICA PANELS

- Range of ex-stock colours available for immediate delivery
- Huge price advantage over most other panel brands
- Allows for doors and fixed panels to be of contrasting colours at no extra charge (conditions may apply)

LAMINEX PANELS

- This range attracts an approx. **30% cost premium** over the Maica range
 - Black core
 - Surface Finish: Texture
 - Sheet size: 1835 x 1820 mm
- For stock colour options please see www.resco.co.nz (Other colours available on request)

ALUMINIUM COLOUR RANGE

- Powder coat colour options can be selected from the DULUX powder coat range on www.duluxpowders.com.au
- Quoted prices are based on category 1 & 2 colours
- Other categories, premium P/C colours and silver anodising prices on request

GUARANTEE

- **10 Year Guarantee** on panel integrity & 2 years on hardware

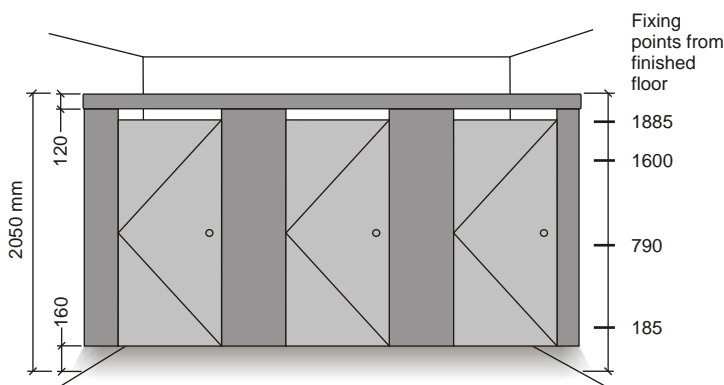
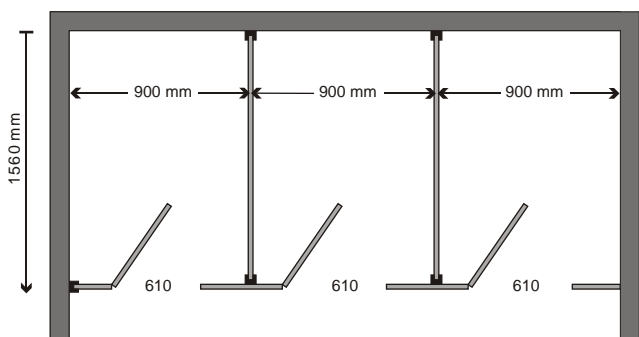

Cubicle depth: 1560 mm (max.)
Cubicle width: 900 mm

For full design parameters contact
multicube@resco.co.nz or phone **07 850 1025**